

Planning Committee

Thursday, 25th April, 2024, 6.00 pm

Shield Room, Civic Centre, West Paddock, Leyland PR25 1DH and
YouTube

Supplementary Agenda

I am now able to enclose, for consideration at the above meeting of the Planning Committee, the following information:

8 Committee Presentation

(Pages 3 - 18)

Chris Sinnott
Chief Executive

Electronic agendas sent to Members of the Planning Committee

This page is intentionally left blank



**South
Ribble**
Borough Council

Page 3

Planning Committee 25th April 2024

Agenda Item 8

Application Number: 07/2024/00110/FUL



Address: 55 Liverpool Road, Penwortham

Applicant: Mr Andy Kirkham

Page 4

Agent: Mr Khalid Khan, Khalid Khan & Associates

Development: Change of use of ground floor from retail (Class (e)) to a Hot Food Takeaway (sui generis) together with the installation of an extraction flue vent to rear

Agenda Item 8

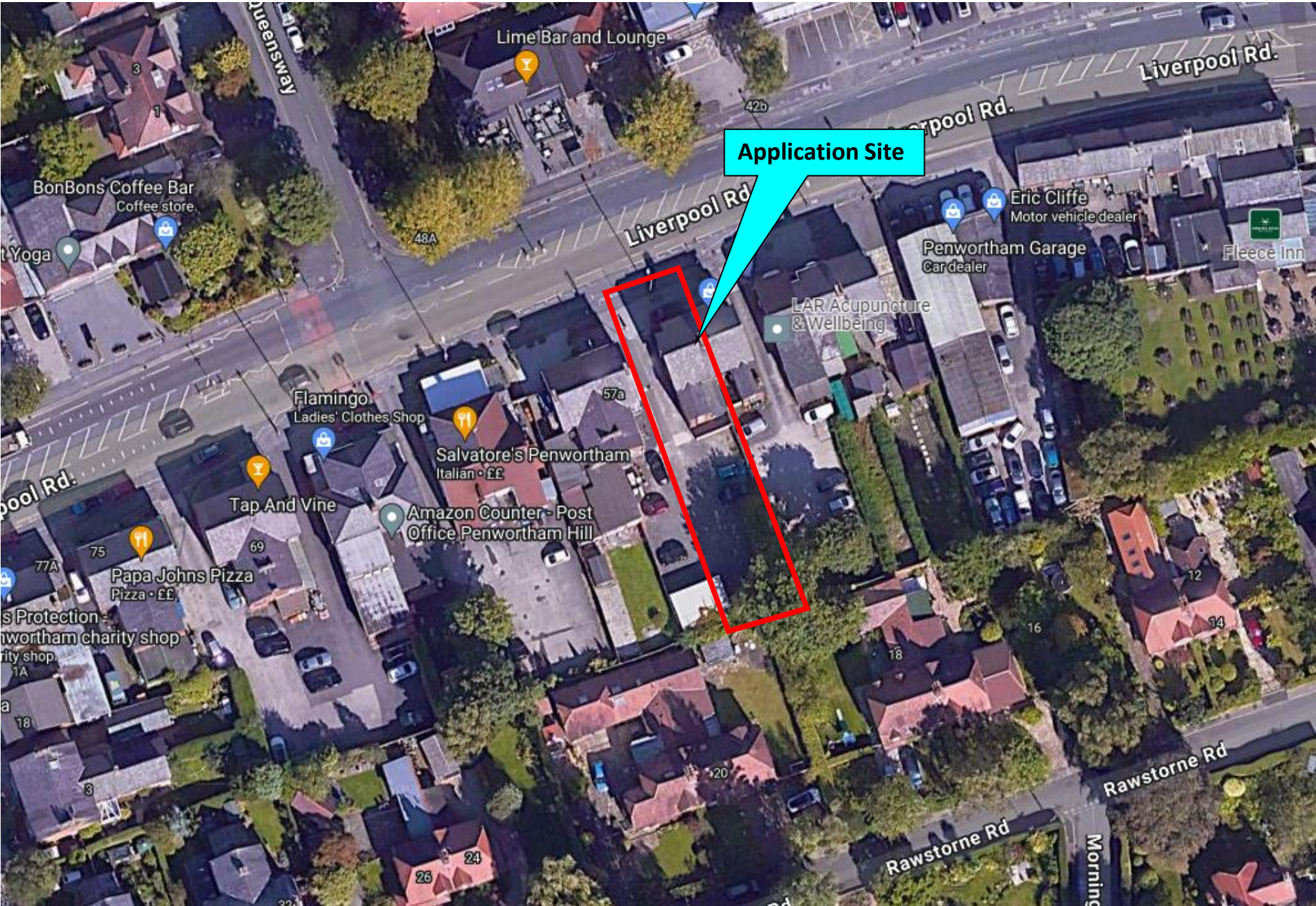



04.03.2024 13:42

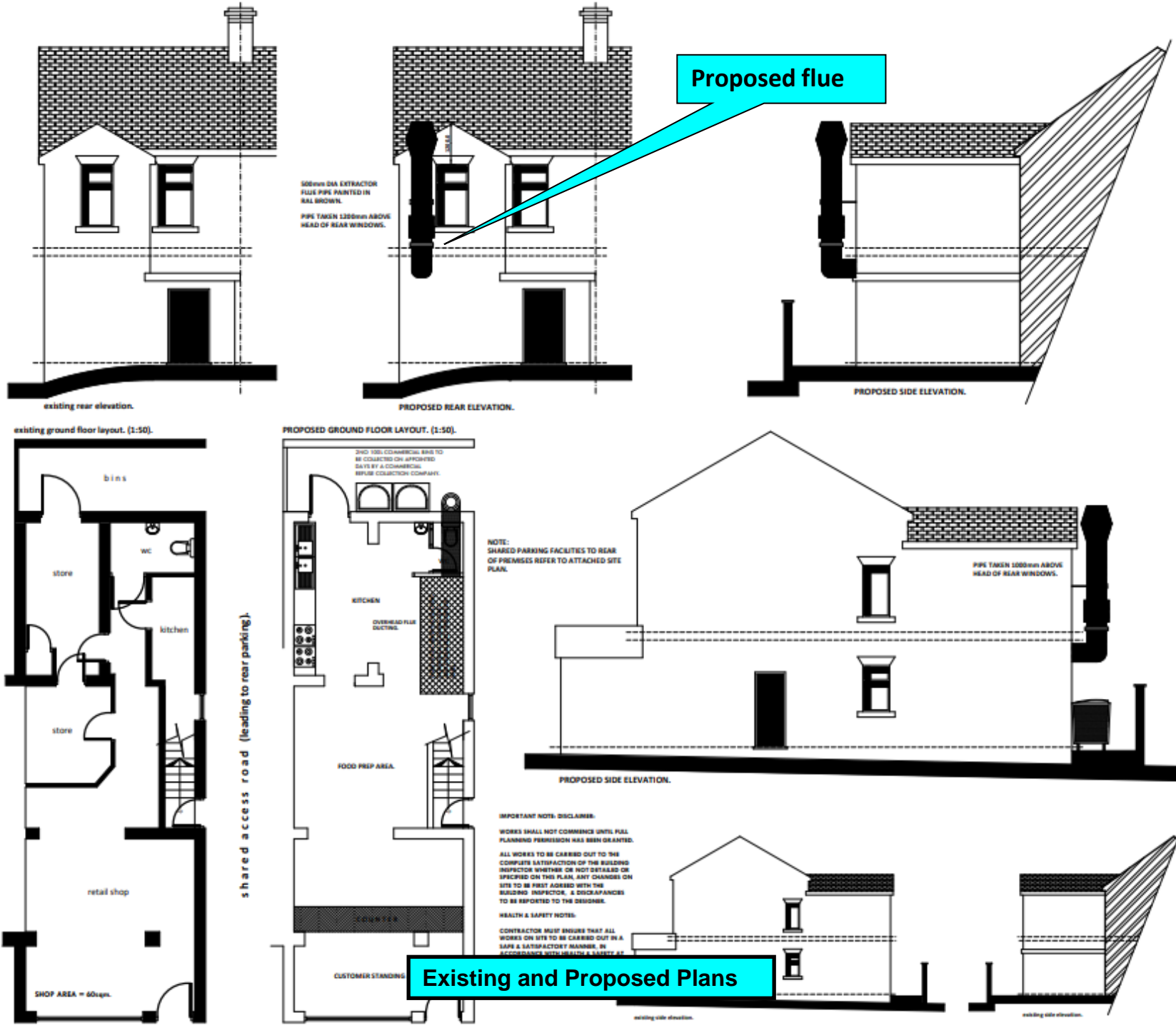

Existing and Proposed Plans

Proposed position of flue

Adjacent first floor flat





Application Site

View of shared car park to rear

04.03.2024 13:41



04.03.2024 13:40

View of residential properties to the rear of the car park on Rawstone Road

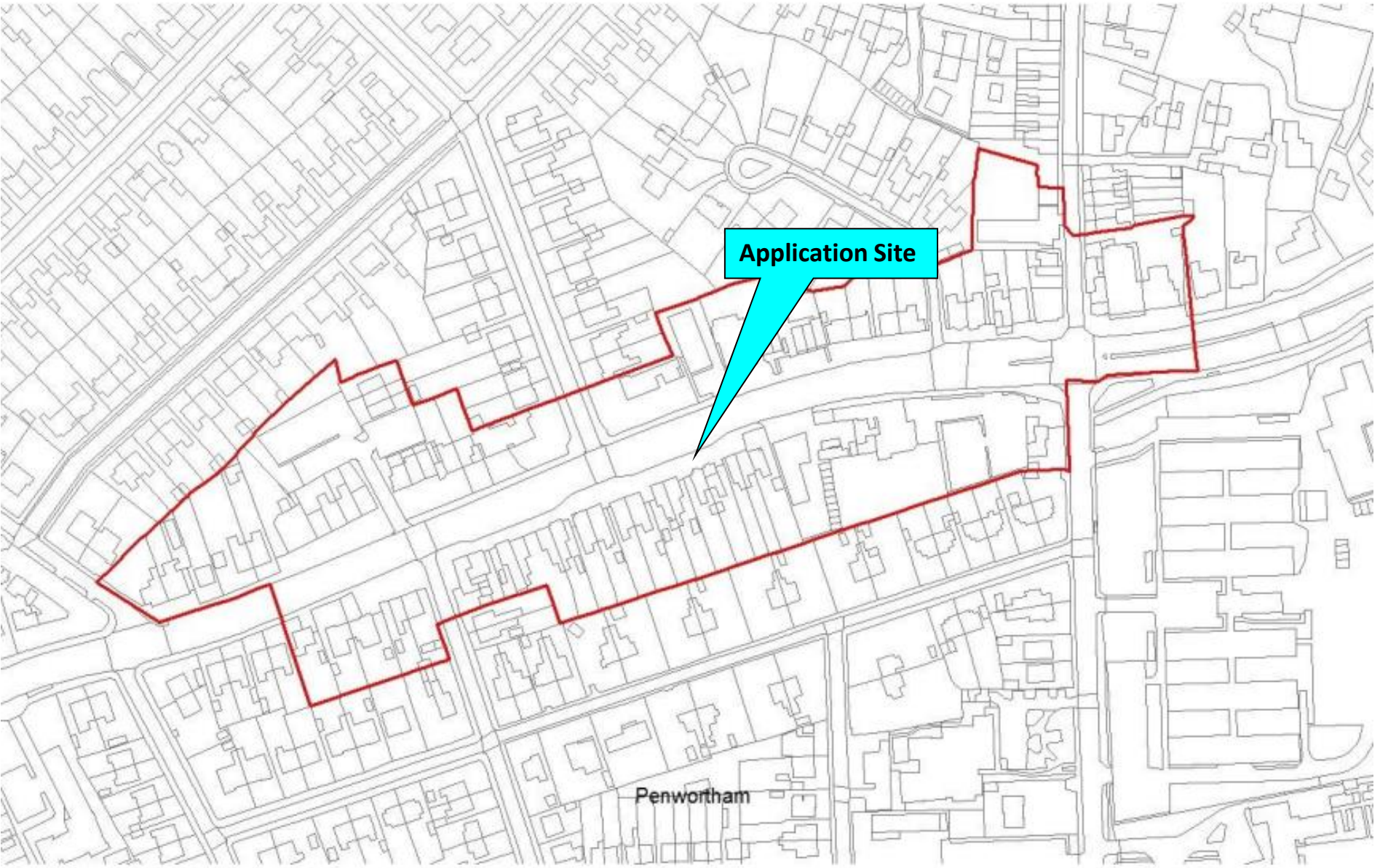

This map is based upon Ordnance Survey material with the permission of Ordnance Survey on behalf of the Controller of Her Majesty's Stationery Office © Crown Copyright. Unauthorised reproduction infringes Crown copyright and may lead to prosecution or civil proceedings. 10001864 1

Penwortham District Centre



 E4 - District Centres

Application Number: 07/2024/00150/FUL



Address: Family Wellbeing Centre, Wilkinson Street, Lostock Hall

Applicant: Mr David Taylor

Agent: Mr Jason Ascroft, South Ribble Borough Council

Development: Siting of storage container unit to car park area adjacent to Family Wellbeing Centre for storage of donated baby items.

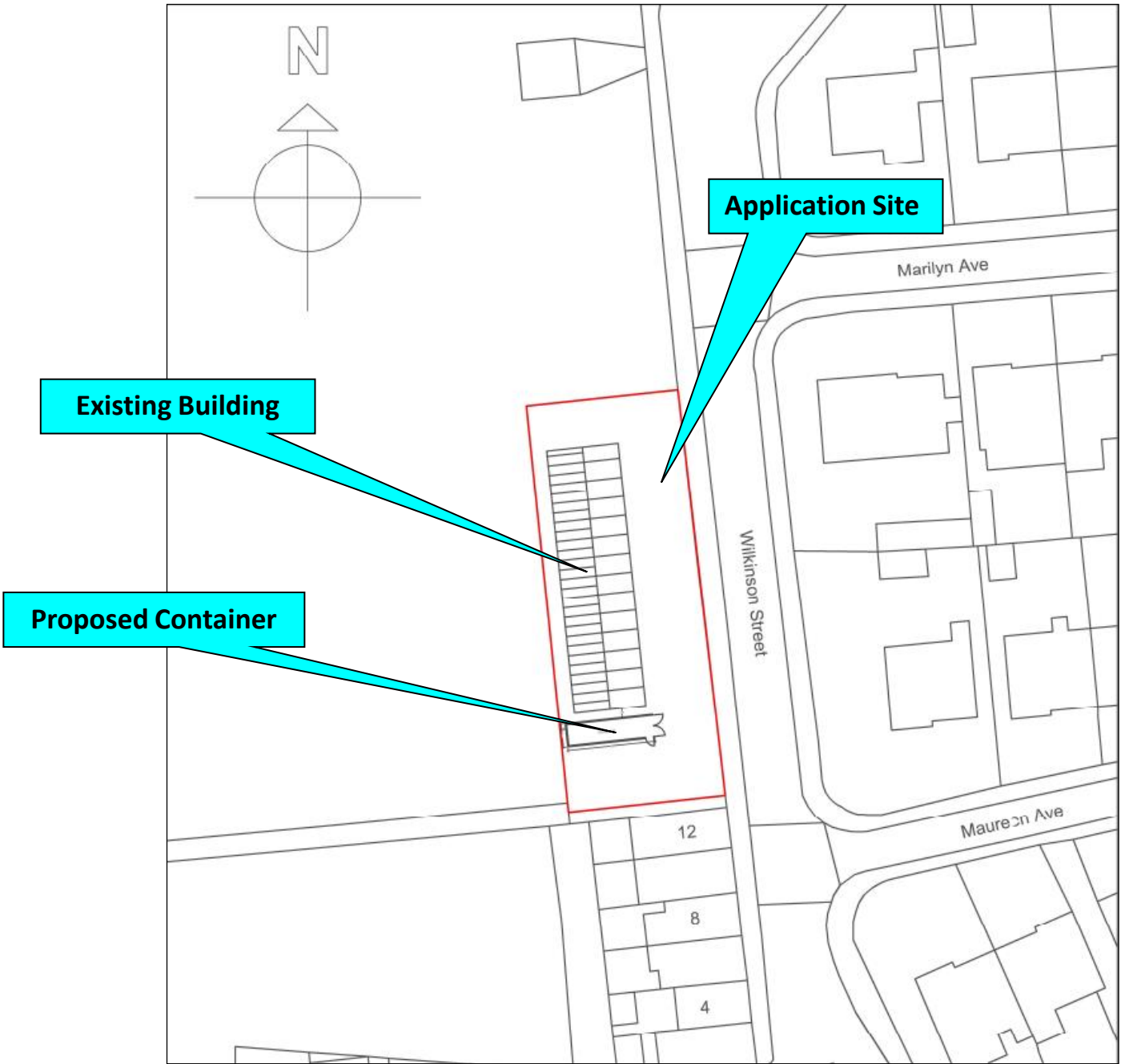



Gable of adjacent dwelling

Existing Wellbeing Centre



Video



Donation Point through door on existing building



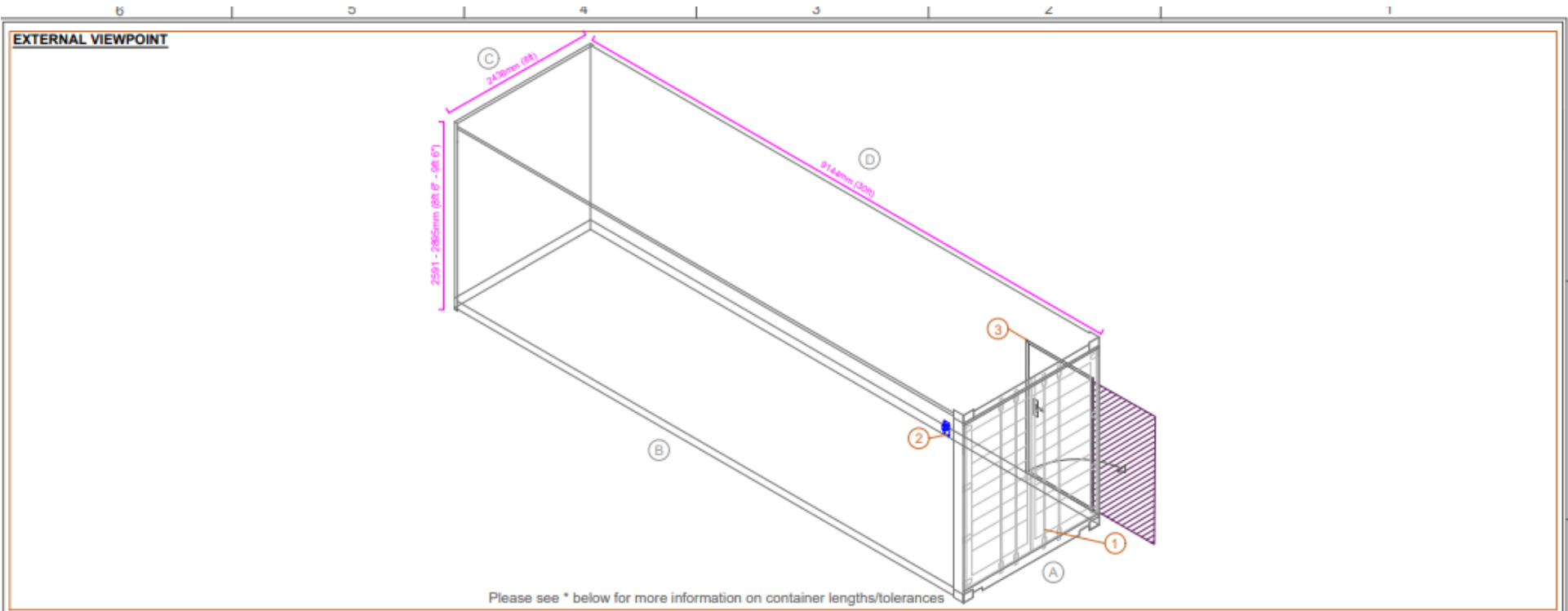

Proposed Container Details

This page is intentionally left blank